

Dialogic® D/82JCT-U PBX Integration Board

Quick Install Card

Dialogic®

Part Number: 64-0089-02
Copyright © 2000-2007
Dialogic Corporation. All rights reserved.

Before You Begin

Protecting the Board from Damage

CAUTION: All computer boards are sensitive to electrostatic discharge (“ESD”). Handle all static-sensitive boards and components at a static-safe work area, and observe anti-static precautions at all times. If you are not familiar with ESD safety precautions, visit <http://www.dialogic.com/support/hwinstall> to learn more.

Unpacking the Board

Unpack the Dialogic® D/82JCT-U PBX Integration board (“board”) according to the following steps:

1. Prepare a static-safeguarded work area.
2. Carefully remove the board from the shipping carton and anti-static packaging. Handle the board by the edges and avoid touching the board’s components.
3. Lay the board on the static-dissipative work surface.

Note: Place boards in static-shielding bags when carrying boards from station to station.

CAUTION: Do not remove the board from the anti-static packaging until you are ready to install it. Observe proper anti-static precautions at all times.

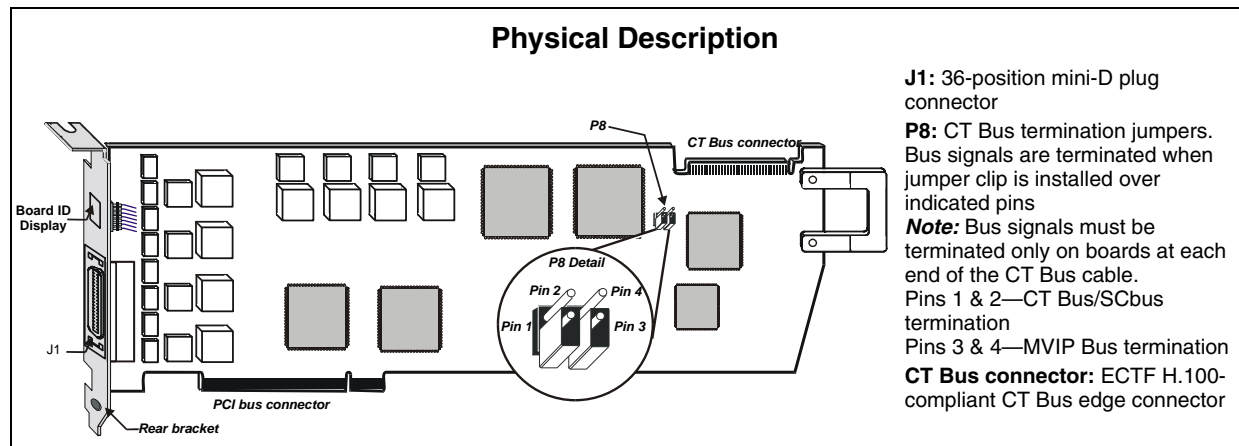

Configuring the Hardware

The Dialogic® D/82JCT-U board is a PCI form factor board that uses hardware auto-configuration for IRQ and memory address. It allows you to use the factory default hardware settings for quick installation and operation. However, you should review the following information to determine if any of the optional configuration items apply to your system.

Setting the Board Identification Number

When you start a Dialogic® board, each board is assigned a Board ID number for identification and use by the application program.

All Dialogic® PCI boards with a rotary switch can share the factory default switch setting and Board ID of 0. To give a PCI board with a rotary switch a Board ID other than 0, the rotary switch is set to the desired number. Because the Dialogic® D/82JCT-U board has no rotary switch, the Dialogic® Configuration Manager (DCM) software that is provided with the board automatically assigns Board IDs, beginning with 0, unless there are other PCI boards with a rotary switch settings of 0, 1, 2, etc. In that case, DCM assigns the first available Board ID not in use.

The Board ID of the Dialogic® D/82JCT-U can only be changed by using DCM. See the DCM help files for more information about changing Board IDs.

Note: If you add PCI boards with rotary switches to your system after Dialogic® D/82JCT-U boards have been assigned, boards may share the same ID, depending on the rotary switch settings of the new boards. For instance, if DCM has assigned Board IDs 01, 02, and 03 to existing Dialogic® D/82JCT-U boards, and then the rotary switches on three new

boards are set to 1, 2, and 3, the Dialogic® D/82JCT-U and new boards will share Board IDs 01, 02, and 03.

The Dialogic® D/82JCT-U Board ID appears on the 2-character LED display on the rear bracket of the board, along with error codes, when appropriate.

Display	Meaning
00-xx	Board ID (in hexadecimal)
88	PCI Bus reset active
D0	Front-end download or initialization failed
E1-E8	Error on PBX port 0-7 (channel 1-8)

Following download, the Board ID is continuously displayed on the LED unless a communications error is experienced on one or more of the PBX ports. When errors are present, they are displayed for two seconds, alternating with the Board ID for two seconds.

CT Bus Termination

Jumpers are used to terminate signals on the CT Bus. These settings apply to boards located at physical ends of the bus. For CT Bus or SCbus, both CT_C8_(A&B) and CT_FRAME_(A&B) are terminated using pins 1 and 2 of the P8 termination jumpers. For MVIP, C-2 and C-4* are terminated using pins 3 and 4 of the P8 termination jumpers.

Note: Only the two boards at the ends of the CT Bus ribbon cable must have their terminations enabled. All other boards must not have the jumper clips installed.

Installing the Board

1. Working with your computer at a static-safe work area, switch off the power and disconnect all power cords from the electrical outlets.
2. Remove the chassis cover.
3. Select an empty PCI expansion bus slot and remove the slot’s retaining screw and access cover plate.
4. If you are not installing your board in an ISA form factor PCI slot, remove the ISA edge retainer bracket from the board.
5. Using the slot’s board guides, insert the edge connector of the board into the bus slot. Press firmly until the board is securely seated in the slot.
6. Replace and tighten the retaining screw to secure the board firmly in the chassis slot. If the screw is not installed, attaching a CT Bus cable can unseat the board from the slot.

Installing the PCI Board

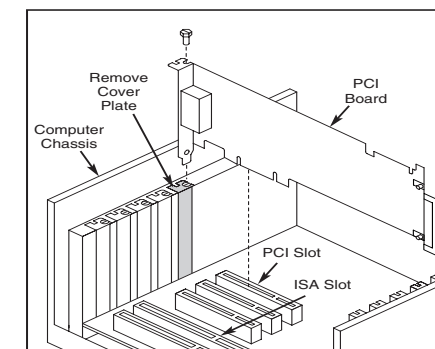

7. Repeat steps 3–6 for each board you are installing.

Connecting the CT Bus Cable

Note: If you are using the Dialogic® D/82JCT-U in “stand-alone” mode, where the application does not use time-slot routing, you do not need to connect a CT Bus cable and you may skip the instructions in this section. You only need to perform this part of the installation if your system uses multiple boards and controls resources on the boards through time-slot routing.

The Dialogic® D/82JCT-U connects to other boards via the H.100-compliant Computer Telephony bus (CT Bus) using an optional CT Bus cable.

Note: Full H.100 capabilities are not available with this release of the Dialogic® D/82JCT-U.

1. Attach the end connector on the ribbon cable to the CT Bus edge connector on the top edge of the first board. The connectors are designed to fit together one way only. If the connector does not seat fully on the board, turn the cable around and try again. Make sure that the colored stripe on the cable faces toward the rear bracket. (The stripe should be adjacent to pin 1 on the board connector.) To preserve the electrical integrity of the CT Bus, use a CT Bus cable with the appropriate number of connectors (“drops”). It is recommended that no more than two connectors at either end of the cable be left unused.
2. Attach the ribbon cable to the next board until all boards are connected by the cable.

Installing the CT Bus Cable

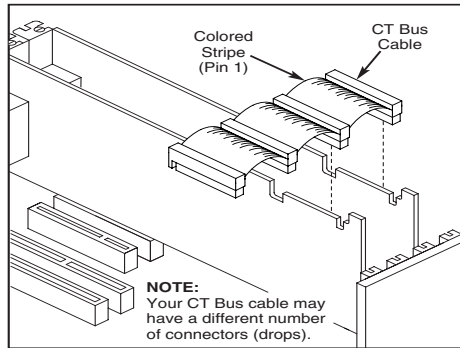

Note: To connect the CT Bus to an SCbus, attach a CT Bus/SCbus Adapter (not included) to the CT Bus board closest to the SCbus, and connect the SCbus cable to this adapter. See the hardware installation instructions for the CT Bus/SCbus Adapter for more information.

3. If the ribbon cable has extra connectors or loose cable, tuck the cable down so that it does not snag when you replace the PC cover.
4. After installing and connecting all the boards, replace the PC cover, cables, and cords.

Connecting External Cabling

A PBX station interface cable assembly that is specific to the Dialogic® D/82JCT-U (available separately) is used to connect the board to a punch-down block.

Connecting the Station Interface Cable

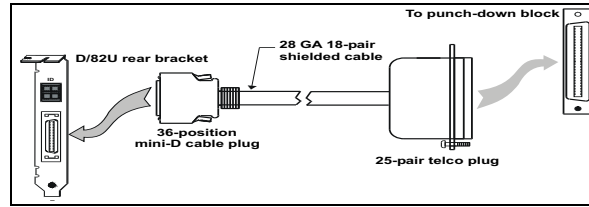

The station interface cable terminates at the punch-down block end with a 25-pair, 57-series Amphenol plug to allow available type-66 punch-down blocks to be used to terminate the PBX station wiring. A 36-position mini-D connector is used on the Dialogic® D/82JCT-U end of the cable.

To connect your Dialogic® D/82JCT-U board to a punch-down block, follow the instructions below:

1. Connect the station interface cable’s 36-position mini-D cable plug to the connector on the rear bracket of the Dialogic® D/82JCT-U.
2. Connect the station interface cable’s 25-pair telco plug to the connector on the punch-down block.

Hardware installation is now complete.

Connector Pin Numbering

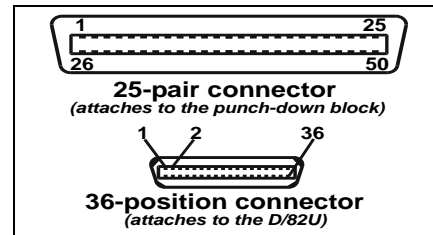

The Telco plug cable connector tabulation is arranged so that the four conductors of one station set circuit are adjacent on a standard, type-66 punch-down block. The pattern shown in the following figure continues down the connector to encompass all eight channels with two pairs of conductors per channel, for a total of 16 twisted conductor pairs.

Telco Plug Connector Pinout

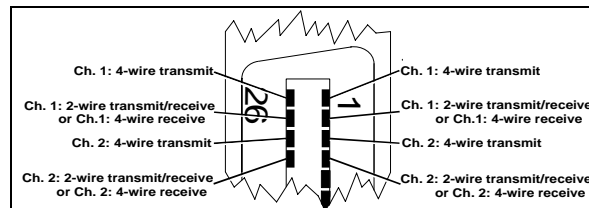

After Installing the Hardware

After installing the hardware, run the Dialogic® Configuration Manager (DCM) as described in the installation instructions included with the Dialogic® System Software to configure your system.

For technical specifications and product information go to: <http://www.dialogic.com/products.htm>.

Warranty and Return Information

Warranty Period

For specific warranty information for this board, refer to the Warranty section of the Products page, located at this URL: <http://www.dialogic.com/warranties/>.

Contacting Technical Support

Dialogic provides technical support for its products through a network of value added distributors who are trained to answer technical questions on installing and configuring Dialogic® products. If you are unsure how to contact your support channel, please call Dialogic in the United States at 973-967-6600 (9am-5pm EST) and we will assist in obtaining the appropriate support channel.

Outside the United States please refer to <http://www.dialogic.com/support/contact> to obtain local contact information. Dialogic also provides direct support via Dialogic® Pro™ Services agreements. For more details of direct support from Dialogic please refer to:

<http://www.dialogic.com/support/DialogicPro>.

Returning a Product

To return a board for warranty repair or any other returns, please refer to the following:

<http://www.dialogic.com/support/hwfaults>.

Sales Assistance

If you have a sales question, please contact your local Sales Representative or the Regional Sales Office for your area. Address, telephone and fax numbers, are available at the Dialogic website located at: <http://www.dialogic.com/contact.htm>.

To purchase Dialogic® products, please refer to the following website to locate the appropriate supplier: <http://www.dialogic.com/purchase.htm>.

All contents of this document are furnished for informational use only and are subject to change without notice and do not represent a commitment on the part of Dialogic Corporation or its subsidiaries (“Dialogic”). Reasonable effort is made to ensure the accuracy of the information contained in the document. However, Dialogic does not warrant the accuracy of this information and cannot accept responsibility for errors, inaccuracies or omissions that may be contained in this document.

INFORMATION IN THIS DOCUMENT IS PROVIDED IN CONNECTION WITH DIALOGIC® PRODUCTS. NO LICENSE, EXPRESS OR IMPLIED, BY ESTOPPEL OR OTHERWISE, TO ANY INTELLECTUAL PROPERTY RIGHTS IS GRANTED BY THIS DOCUMENT. EXCEPT AS PROVIDED IN A SIGNED AGREEMENT BETWEEN YOU AND DIALOGIC, DIALOGIC ASSUMES NO LIABILITY WHATSOEVER, AND DIALOGIC DISCLAIMS ANY EXPRESS OR IMPLIED WARRANTY, RELATING TO SALE AND/OR USE OF DIALOGIC PRODUCTS INCLUDING LIABILITY OR WARRANTIES RELATING TO FITNESS FOR A PARTICULAR PURPOSE, MERCHANTABILITY, OR INFRINGEMENT OF ANY INTELLECTUAL PROPERTY RIGHT OF A THIRD PARTY.

Dialogic products are not intended for use in medical, life saving, life sustaining, critical control or safety systems, or in nuclear facility applications.

It is possible that the use or implementation of any one of the concepts, applications, or ideas described in this document, in marketing collateral produced by or on web pages maintained by Dialogic may infringe one or more patents or other intellectual property rights owned by third parties. Dialogic does not provide any intellectual property licenses with the sale of Dialogic products other than a license to use such product in accordance with intellectual property owned or validly licensed by Dialogic and no such licenses are provided except pursuant to a signed agreement with Dialogic. More detailed information about such intellectual property is available from Dialogic’s legal department at 9800 Cavendish Blvd., 5th Floor, Montreal, Quebec, Canada H4M 2V9. **Dialogic encourages all users of its products to procure all necessary intellectual property licenses required to implement any concepts or applications and does not condone or encourage any intellectual property infringement and disclaims any responsibility related thereto. These intellectual property licenses may differ from country to country and it is the responsibility of those who develop the concepts or applications to be aware of and comply with different national license requirements.**

Dialogic, Diva, Eicon, Eicon Networks, Eiconcard and SIPcontrol, among others, are either registered trademarks or trademarks of Dialogic. Dialogic’s trademarks may be used publicly only with permission from Dialogic. Such permission may only be granted by Dialogic’s legal department at 9800 Cavendish Blvd., 5th Floor, Montreal, Quebec, Canada H4M 2V9. Any authorized use of Dialogic’s trademarks will be subject to full respect of the trademark guidelines published by Dialogic from time to time and any use of Dialogic’s trademarks requires proper acknowledgement. The names of actual companies and products mentioned herein are the trademarks of their respective owners.